

Interfacing with the UltraVolt M and V Series of Microsize High Voltage Power Supplies

Introduction

In this technical note, we provide the connections, pins and leads for the UltraVolt M Series and V Series of microsize high-voltage power supplies. This document augments the data sheet for each series. Complete data sheets can be found below:

http://www.ultravolt.com/uv_docs/MSeries.pdf

http://www.ultravolt.com/uv_docs/VSeries.pdf

M and V Series microsize units deliver 0-600 volts through 0 to 3kV in a 0.5W, 0.8W or 1W miniature package. The nominal input voltages available are 5Vdc, 12Vdc, 15Vdc and 24Vdc. See data sheet for specific models.

While electrical specifications are identical, the M is horizontal mount unit and the V is a vertical mount unit with a smaller PC board footprint.

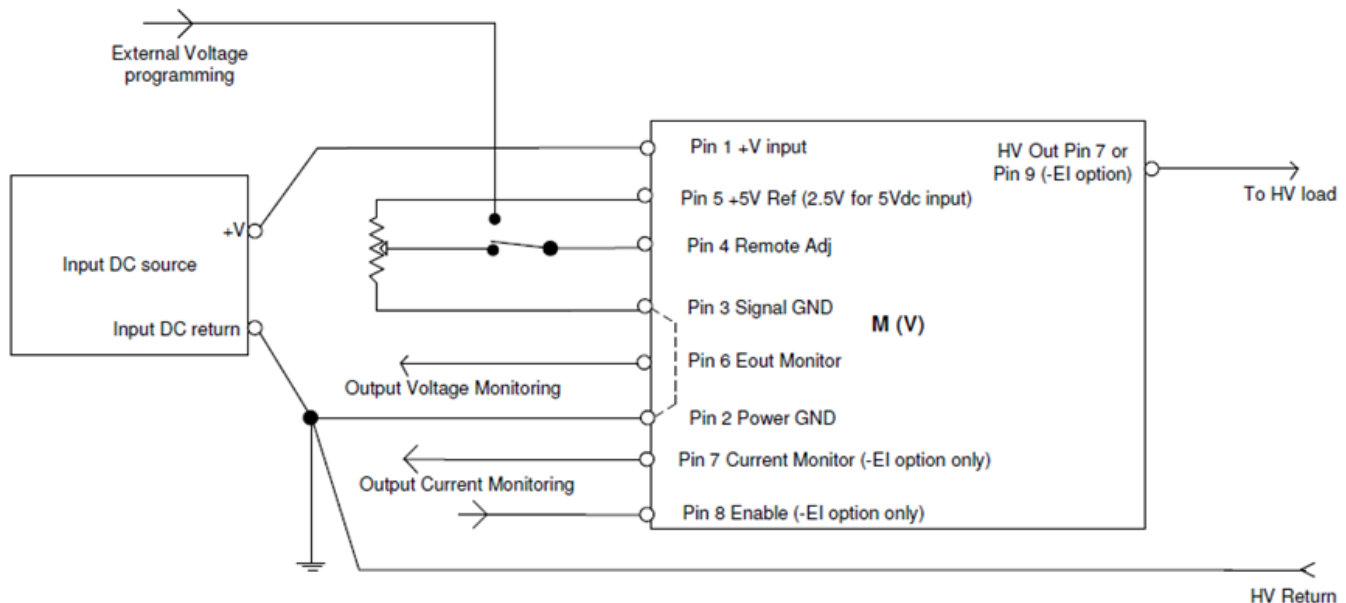

Figure 1: M and V Series Functional Diagram

Connections Overview

Pin 1, Positive Power Input:

This pin is the positive power input (5, 12, 15 or 24Vdc) coming from the system AC/DC, DC/DC or battery low voltage power source. The input source must be capable of providing at least 120% of the maximum input current required by the M or V Series unit at full load (see [M Series](#) or [V Series datasheet](#) for more details).

Pin 2, Input Power Ground Return:

This pin is the return to the input DC source and is separate from the signal ground. Connection to this pin is also used in the system as the HV Return.

Pin 3, Signal Ground:

This pin is used as return for the voltage control and monitor signals. It is provided as a separate ground for low power signals in order to avoid any interference with the High Voltage (HV) and Input Power returns. Do not use this pin as a direct connection to the HV return. This pin is internally connected to Input Power Ground return.

Pin 4, Remote Adjust Input:

This pin allows the control of the high-voltage output by a low-voltage analog signal. The high voltage can be controlled from 0 to 100% by using a 0 to 5V positive voltage (for 12, 15 and 24Vdc input) or a 0 to 2.5Vdc (for the 5Vdc input). The control voltage signal source can be a DAC, op amp, etc. or a voltage derived from the internal reference (pin 5) via a potentiometer. For Pin 4, input impedance is 1M Ω . If a potentiometer is used in conjunction with the internal reference, we recommend values between 10k Ω to 100k Ω . The control voltage is positive in reference to signal ground for units with either output polarity (positive HV or negative HV). If zero volts is provided (or no connection) there will be no output voltage available.

Pin 5, Reference Voltage:

For units with 12, 15 and 24Vdc input, a +5V \pm 0.5% reference voltage with a temperature coefficient of 50ppm/ $^{\circ}$ C and 1mA maximum current is available. For the 5VDC input units, the reference voltage is 2.5Vdc. This reference voltage can be used to program the output voltage via an external potentiometer or resistive divider.

Pin 6, Output Voltage Monitor:

For units with maximum output voltage of 600, 1000, 1250 and 1500Vdc, this pin provides a low voltage proportional with the High Voltage Output via 1000:1 divider (1V per 1kV output). For positive polarity units, the voltage monitor is positive in reference to return; for negative polarity outputs, the monitor voltage is negative in reference to return. The grounded side of the divider has 200k Ω \pm 1% impedance. Please take this value into account when the voltage monitor is connected to a system with low input impedance. For example, using a digital voltage meter (DVM) with 10M Ω input impedance, the nominal error is about 2% (you read 0.980V instead of 1V when the HV output is at 1000V. A 1M Ω input impedance meter will give a nominal error of 16.7% (it would read 0.833V instead of 1V for HV output at 1000V). The divider is linear and proportional over the entire range; therefore, the numerical error can easily be compensated in the system. We recommend the use of a high impedance buffer.

The 2kV, 2.5kV and 3kV output voltage units have a buffered E monitor with a 0-5V linear scale (or 0-2.5V scale for 5 Vdc input unit only). The output impedance is 1k Ω . The E monitor voltage is positive in reference to signal ground regardless of output voltage polarity.

Pin 7, High Voltage Output:

This pin is the high-voltage output (up to 3000V depending on the model). The pin is located farther away from the other pins in order to provide the proper clearance for the high voltage. When designing the system PC board, the proper creepage and clearance spacing must be observed.

Flying Lead option:

Instead of pin 7, M and V Series units can have the high-voltage output provided via a flying lead. (See option in the product datasheet.)

On units with the –EI Option, high-voltage output is available on Pin 9.

Pin 7, Current monitor (2kV, 2.5kV and 3kV units with –EI option):

The 2kV, 2.5kV and 3kV units with –EI option have a buffered output current monitor with a 0-5V scale (or 0-2.5V scale for 5 Vdc input unit only). The output impedance is 1k Ω .

Pin 8, Enable, (2kV, 2.5kV and 3kV units with –EI option):

Enable/Disable (ON/OFF): 0V to +0.5V =Enable, +2.4V to Input DC =Disable (Default = Disable).

Pin 9, High Voltage Output for 2kV, 2.5kV and 3kV units with –EI option.

In units with the –EI option, pin 7 is used for current monitor function and the additional pin 8 for the Enable function. In these units, high-voltage output is available on pin 9.

Optionally (instead of pin 9), the output is also available via a flying lead.

The -EI option is available only in units with 2kV, 2.5kV or 3kV output.

Case metal tabs:

M and V Series units are encapsulated in a tinned steel case with mounting tabs. The case and tabs are internally connected to the input power return. We recommend soldering the tabs to the system ground plane (See tab locations and dimension in the product [datasheet](#)).